

The MCB-200 is a bistation microwave detector for outdoor applications. It comprises a transmitter (T) and receiver (R) which, when mounted facing each other, create a protected area with length up to 200m. Width of the protected area vary, according the distance between the two units and the selected system sensitivity.

The Microwave barrier MCB-200 is an advanced detector utilizing state of the art Microwave technology eliminating false alarms while maintaining high security standards for the detection of human intruders into a protected area.

The MCB-200 is designed to protect large part of protected perimeter and can easily be installed on any type of fence or pole in order to provide a solid barrier protection and block all perimeter activities; this barrier rejects alarms from birds and small animals (like a cat) due to its original method of false alarm elimination.

Several MCB-200 systems can be combined in order to provide a complete perimeter protection with unlimited space or shape.

The MCB-200 is designed for continuous round-the-clock operation and keeps its characteristics within a wide temperature range of **-40°C up to +65°C** and a relative humidity of up to **98%**.

Features:

- Detection Range: MCB-100: Up to 100m
MCB-150: Up to 150m
MCB-200: Up to 200m
- Operating Temperature: -40°C to +65°C
- Power Input: 10.2~30Vdc
- Detection human intruders walking, running or crawling.
- Quick and easy installation on pole, fence or wall.
- No maintenance required.
- High RFI/EMI Immunity.
- Protection form: direct sunlight, wind up to 30 m/sec, snow and rain precipitation (up to 30mm/hour), small animals, ground swing, snow and grass up to 0.3m.
- Making alarm when: Human intruders walking, running or crawling with speed from 0.2 till 10 m/s, applying 5-30Volts from control unit to the terminal marked.

TEST (on the transmitter unit), power supply voltage less than 10.2V, transmitter or receiver cover has been opened or destructed, electromagnetic masking of the receiver.

Installation instructions.

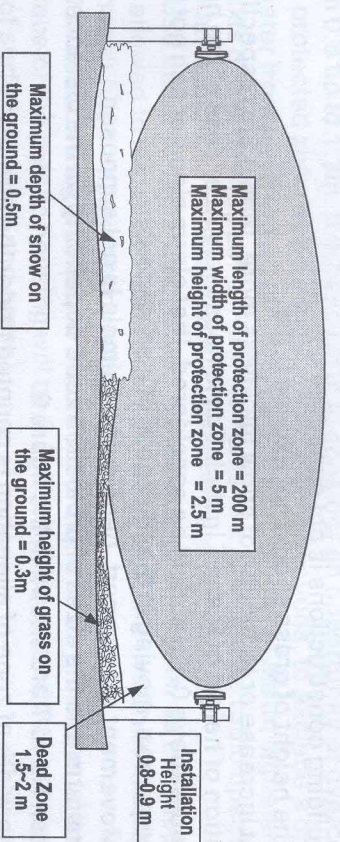

Fig. 1. Installation and Protection zone

Mounting the detector

Alarm LED

- «Alarm» - LED shines for a while (not less than 2 sec., but no more than 30 sec.);
- «Protection» - LED does not shine;
- «Power supply less than should be» - LED blinks with the period 2 sec (1 sec shines and 1 sec - switched off);
- «Invalid parameters of initial installation» (a level of an accepted signal less than 9 Db) - LED blinks with the period 2 sec. (0.25 sec. - shines and 1.75 sec. switched off);
- «Fault» - LED on the control panel shines constantly.

Installation

Installation on Pole

Attention! The reliability of alarm signaler work depends on the fulfillment of the following requirements. By the no fulfillment of these requirements, infringements of alarm signaler working capacity are possible. In such cases the question of an admissibility of alarm signaler application in the given conditions is defined by experimental exploitation.

In protection zone:

The maximal height of roughness's of a spreading surface concerning the direct line which is passing through the bases of R(receiver) and T(transmitter) support, should not exceed $\pm 0.3m$.

-Presence of bushes and branches of trees, large motionless subjects and building constructions is not supposed.

-The height of grass should not exceed 0.3m.

-At increase or reduction of snow thickness more, than 0.3m respective alteration of height of R and T installation is necessary. At excess of the height of a snow above 0.7m should be considered, that alarm signaler can not find out the person, moving in the thickness of a snow cover.

-Movement of transport, people and animals is not supposed.

The form and the sizes of protection zone depending on the distance between Rand T are shown in the figure 2.

The width of zone of alienation is counted under the formula:

$$W = (1 + L/50)m$$

$$L = (15 - 200)m$$

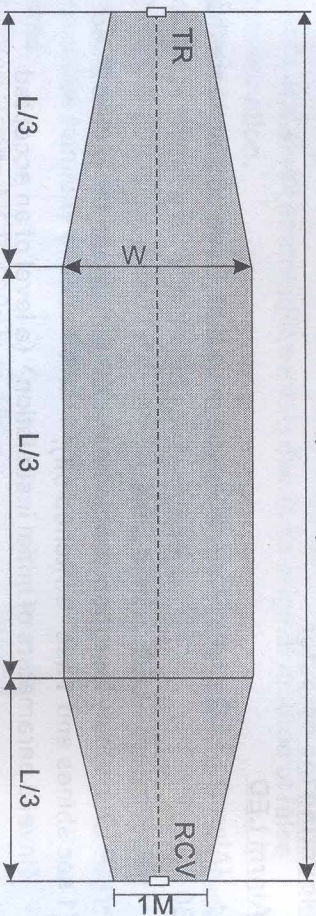

Fig.2

By the choice of an installation site for exception of influence of interference at the alarm signaler work, following recommendations should be considered in addition:

- Routes of movement of groups of people (up to three person) or cars (in case of movement along a site), presence of mobile subjects and designs (including large forests) are supposed on the distance not closer than 2 m from the borders of protection zone;

- Distance from borders of protection zone up to motorways with intensive movement and railways there should not be less than 3m;

- Sites of blocks installation should be removed from electric main wires in the distance not less than 20 m at a pressure up to 35 kv and 30 m at a pressure up to 500 kv. By their arrangement in parallel with electric mains it is recommended to lay connecting lines in the underground way.

Installation of the alarm signaler along flat surfaces of constructions (fencings and walls of buildings) is supposed. Thus roughnesses of these surfaces should not exceed $\pm 0.3m$. Distance from the surface of these

constructions up to installation sites of the alarm signaler blocks should be from 0.6 up to 1.2m. It is necessary to consider an opportunity of overcoming of a protected zone by a jump from these constructions, to exclude a drain of water from a roof on distance up to 5 m from blocks of alarm signaler, on an axis of a protected zone. Requirements to a site outside radio opaque (metal, reinforced concrete, etc.) obstacles are not shown.

Use metal or cement poles with a diameter of 30~40mm as the support. It is allowed to install two units on a single support; the two units must be identical (Two transmitters or two receivers).

Installation height of R and T units should be in a way, that the bottom surface of the plastic housing will be 0.8~0.9m (Very important) above the top of surface (ground and grass).

For pole installation use the two bands connected to the bracket and ensure reliable fastening of the bands. The unused part of bands may be cut off.

Connect the plastic housing to the bracket using the nuts with the spherical support.

Top installation.

Alarm signaler installation on top of fencings for detection of overclimb is supposed. Thus: the height of installation of blocks should be not less than 0.2m from the top of a fencing and not less than 2m - from the surface of the ground, the maximal length of the protection zone should be no more than 100m, the distance from the top of a fencing up to blocks across - not less than 0.2m. the immovability of the fencing and alarm signaler blocks, concerning the fencing should be provided. The ledges of fencings and walls should not block an axis of a protected zone. In case of a deviation of a line of a protection from a straight line, and also at presence of the ledges which are not overlap an axis of the protected zone on, specification of installation site of (T(R)) can be demanded in the experimental way.

The note - At the installation of alarm signaler along constructions or on top of protections manual adjustment of thresholds is recommended.

The support should be mechanically connected to the fence to ensure reliability.

NOTE: It is necessary to exclude a drain of water from a roof closer than 5 meters from an axis of a zone of detection.

Cross installation.

In order to avoid "dead zones" under aerials, and to increase the protected area, it is possible to install multiple MCB-200 systems connected together with overlapping. Overlap configurations are performed with the units located at the angles of protected area. The minimum overlap for sufficient coverage must be at least 1.5~

2m, (depending on the sensitivity set and installation height). The optimal way is to install transmitters (T) only or receivers (R) only at the point of overlap.

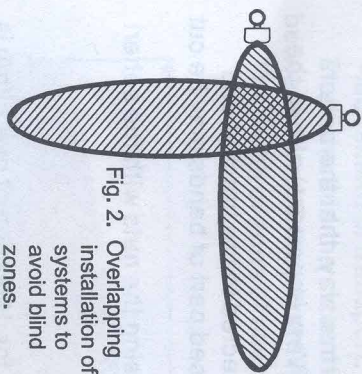

Fig. 2. Overlapping installation of 2 systems to avoid blind zones.

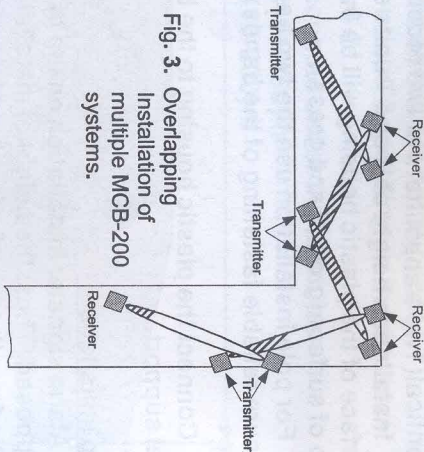

Fig. 3. Overlapping installation of multiple MCB-200 systems.

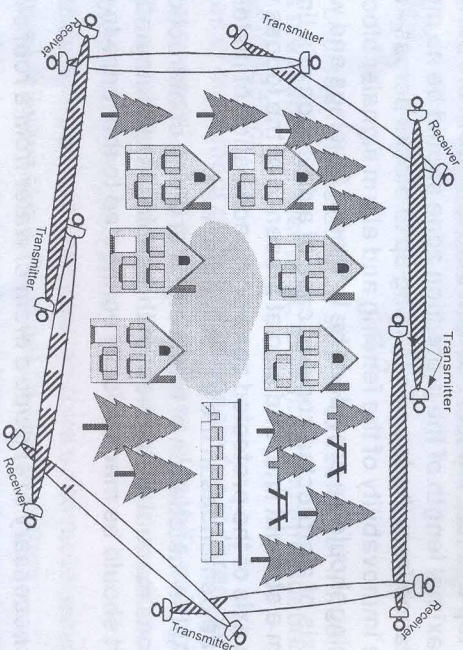
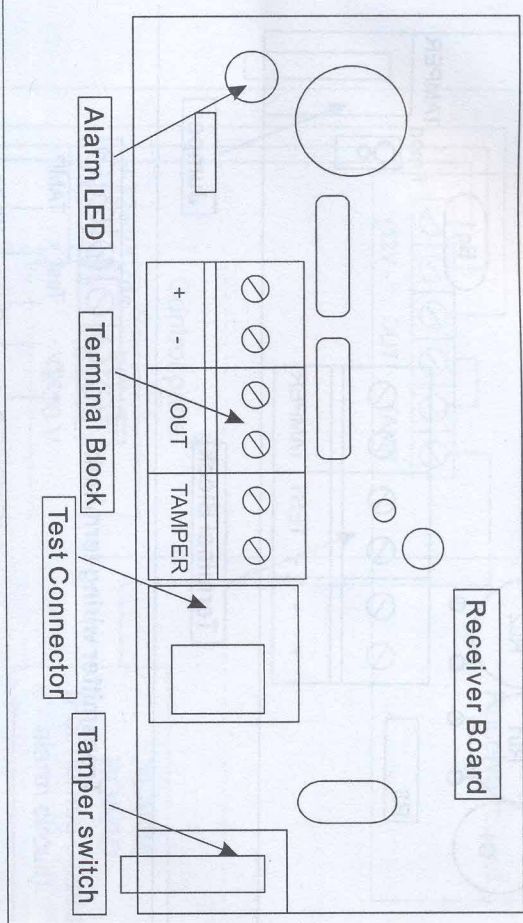

Fig. 4. Overlapping Angle and Range Installation of MCB-200 systems for area protection.

TERMINAL BLOCK CONNECTIONS

Fig. 5. PCB Layout



Receiver wiring terminal:

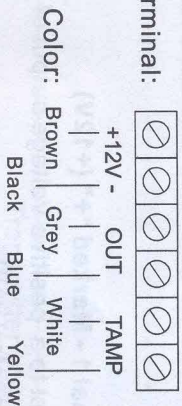

Terminal 1 - Marked "+" (+12V)
Connect to a positive Voltage output of 12 - 30Vdc source (usually from the alarm control unit).

Terminal 2 - Marked "-" (-12V)
Connect to the negative Voltage output of the control unit.

Terminal 3 & 4 - Marked "OUT"

These are the output relay contacts of the detector. Connect to normally closed zones in the control unit.

Terminal 5 & 6 - Marked "TAMPER"

connect these terminals to a 24-hour normally closed protective zone in the control unit. If the front cover of the detector is opened, an immediate alarm signal will be sent to the control unit.

CONTROL UNIT WIRING CONNECTIONS

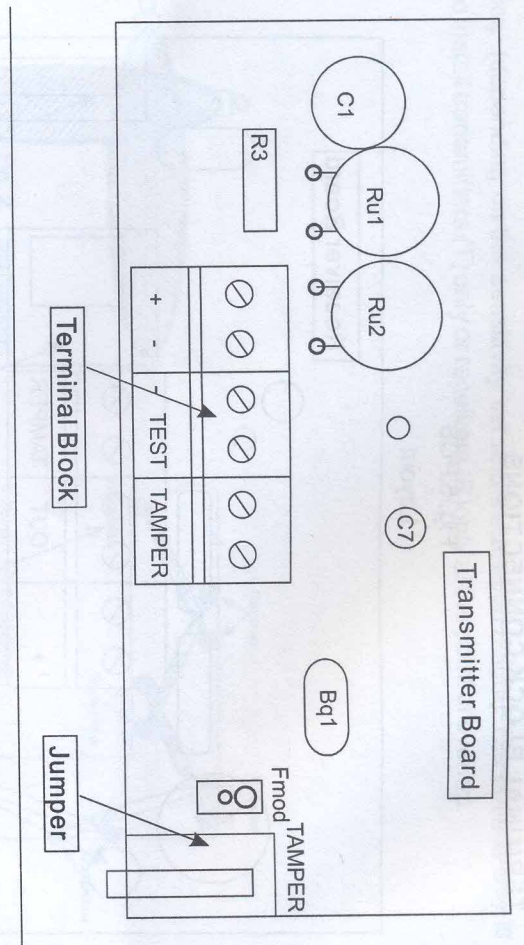

Transmitter wiring terminal:

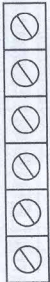

Color: Brown Grey White
Black Blue Yellow

Terminal 1 - Marked "+" (+12V)

Connect to a positive Voltage output of 12 - 30Vdc source (usually from the alarm control unit).

Terminal 2 - Marked "-" (-12V)

Connect to the negative Voltage output of the control unit.

Terminal 3 - Marked "-" (-12V)

Terminal 4 - Marked "TEST"

The alarm signaler makes alarm during the test signal (5-30 Volts) from alarm station feeding in this terminal.

Terminal 5 & 6 - Marked "TAMPER"

connect these terminals to a 24-hour normally closed protective zone in the control unit. If the front cover of the detector is opened, an immediate alarm signal will be sent to the control unit.

F mode Jumper - Setting of Frequency channel - **Factory setting OFF position**

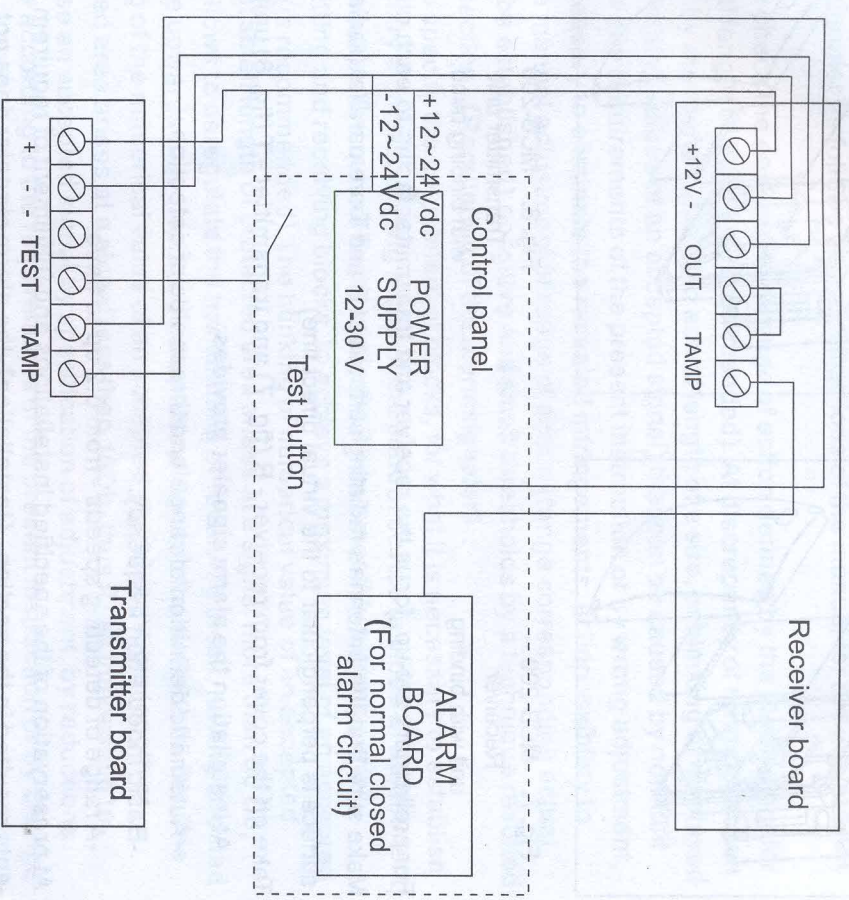

Fig. 6. Control Unit and MCB-200 Wiring Diagram

TEST AND TUNING

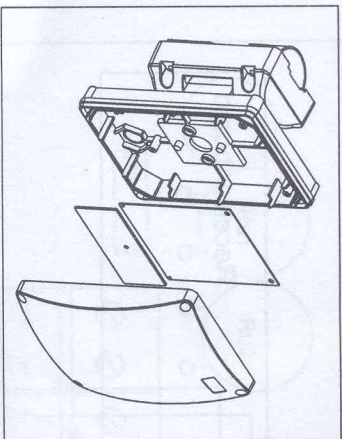

Fig. 7. MCB-200 -
Receiver
unit with binding

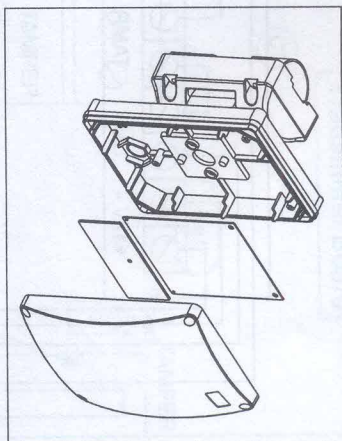

Fig. 8. MCB-200
- Transmitter unit
with binding band.

For preliminary set-up, focus the receiver and transmitter facing to each other. Make sure that the antennas radiating surfaces of R and T are parallel (radiating surface is perpendicular to the virtual direct line).

Take off the cover from receiver - R (fig. 7) and transmitter - T (fig. 8) units.

At installation the alarm signaler provides:

- Automatic definition of range and thresholds of detection.
- Basic modulation frequency.
- A range of detecting speeds - from 0.2 up to 6m/s.

At preservation of the specified installations and fulfillment of requirements resulted in the section «Installation» the alarm signaler does not demand adjustments with use of any devices.

The resulted installations, and also thresholds of detection can be changed by means of the calibration unit «DigiTool». Manual regulation of the alarm signaler allows to provide functioning of the alarm signaler at some deviations of conditions of operation from requirements of the present management, and also to lead updating of the alarm signaler characteristics proceeding from tactics of protection of concrete object.

At inclusion of a feed in case of absence of movement in the zone of alienation, The alarm signaler is established in an on duty mode during no more than 30 sec.

Thus output relay contacts of the alarm signaler are closed. For control of functioning of the alarm signaler it is necessary to open a cover of the receiver unit, connect the calibration unit and to check the functioning of the alarm signaler as follows using instructions of the manual for the adjustment panel.

1) To check the conformity of range of action defined by the alarm signaler to actual length of a site (is recommended). At discrepancy of range of action defined by the alarm signaler to actual length of a site, or blinking of displayed value (limiting values of an accepted signal) that can be caused by nonfulfillment of any requirements of the present instruction or by wrong adjustment, it is necessary to eliminate the revealed infringements, at impossibility to execute manual adjustment of range of action (range corresponding actual should be established), positive and small thresholds by a technique resulted in the section «Regulation of the alarm signaler».

2) To specify the adjustment of blocks, for what it is necessary to establish preliminary a corresponding mode of the control device (a mode of adjustment) and to weaken the nuts of fixing of blocks. Then, smoothly turning serially transmitting and receiving blocks, to achieve a maximum level of an accepted signal (is recommended). The blinking of numerical value of an accepted signal at small length of protected area arises at a signal more than 66 Db, thus follows to deregulate the transmitting or receiving block, having directed it a little upwards that displayed value was within the limits of 62-65 Db. The blinking of the numerical value of an accepted signal at the big length of protected area arises at a signal less than 10Db, thus if it is impossible to increase an accepted signal by specification of adjustment, by reductions of a site according to the requirements of the present instruction or by change of an installation site of blocks, the decision on an admissibility of alarm signaler application in the given conditions is defined by the experimental exploitation. It is necessary to consider, that in some cases at adjustment the maximum level of an accepted signal is reached in the direction of blocks aside nearby reflecting surfaces (fencings, the surface of the ground, etc.). In such cases adjustment with use of the device of the control is not supposed. In case if thus the device of the control displays noise (the changes of the signal which has not been caused by the movement of a person in the protected zone) it is necessary to arrange on the elimination of their sources, at impossibility - to change an installation site, to reduce the extent of a site. Such noises having usually casual acyclic character, can be caused by movement of subjects, the vegetation shaking on the wind. Other probable reason of the noise, having regular periodic character, can be the influence of radiation of

the next sites transmitters on the reception block. The revealing of such influence is made by switching-off of a feed of the next transmitting blocks. At revealing of the influence it is necessary to change frequency of alarm signaler modulation, having removed the corresponding crosspiece on the transmitting block and having changed the value of frequency on spare by means of the calibration unit.

3 To change the range of detecting speeds (if necessary). Desired value borders of detecting speeds are defined by service of operation proceeding from features of the object, a protected site and tactics of protection.

4 To check (necessarily), by means of the control device formation of notices on alarm, for what to execute control crossings of zone of alienation on all length of a site, choosing places of passes in hollows, on eminences. In case of the absence of the notice at crossing of the protected zone it is necessary to execute the actions described in section «Use of a product».

5 To make the remote control (in case of use of this function), having submitted on the output «TEST» a pressure 5-30v, thus the alarm signaler should give out the notice of alarm. During the use of the alarm signaler it is recommended to realize a remote control each 8 hours.

To lead the approbation of the alarm signaler work by trial round-the-clock alarm signaler operation during the period not less than 3 days with registration of all notices and their subsequent analysis. thus not less than two times a day to make a check of the working capacity of the alarm signaler by control crossings of the protected zone.

At revealing false notices at check or misses at control crossings it is necessary to eliminate infringements, using instructions of section «Use of a product».

THE LIST OF THE BASIC POSSIBLE MALFUNCTIONS AND WAYS OF THEIR ELIMINATION

| External display | The possible reasons of malfunction | Ways and sequence of the definition of malfunction |
|--|---|--|
| 1. The alarm signaler constantly gives out the notice on circuit OUT, indication at connection of the calibration unit is absent. | No supply voltage | To check supply voltage of the receiving block. |
| | The receiving block is not serviceable | To replace the receiving block. |
| 2. The alarm signaler constantly gives out the notice on circuit OUT, indication at connection of the calibration unit corresponds to normal functioning. | Circuit OUT is broken | To check up integrity of circuit OUT by "procalls". To check up correctness of installation of a terminal element of the control device. |
| | The receiving block is not serviceable | To replace the receiving block. |
| 3. The alarm signaler constantly gives out the notice on circuit TAMPER. | Circuit TAMPER is broken | To check up integrity of circuit OUT by "procalls". To check up correctness of installation of a terminal element of the control device. |
| 4. The alarm signaler constantly gives out the notice on circuit OUT, the calibration unit in a mode of indication of notices gives out the message «Pow». | Wrong installation of a cover of one of blocks. | To check correctness of installation of covers. |
| | The pressure of a feed is less than norm. | To check the pressure of a feed of the switched on alarm signaler, to check up circuits of a feed and a power unit. |

| | | |
|--|---|--|
| 5. The alarm signaler constantly gives out the notice on circuit OUI, on the calibration unit is constantly shown the message «A». | Discrepancy of installation or conditions of operation to require management of the present management. | To estimate visually the correctness of installation and a conditions of operation on conformity to requirements of section installation. To eliminate deviations, at impossibility to lead adjustment. |
| | The receiving block is not serviceable | To replace the receiving block. |
| | The transmitting block is not serviceable. | To replace the transmitting block. |
| | Discrepancy of installation or conditions of operation to require management of the present management. | To lead the control of functioning, to estimate correctness of installation and conformity of conditions of operation to requirements of section installation. To eliminate deviations, at impossibility to lead regulation. |
| 6. Frequent false notices | Influence of radiation of the transmitting block of the next site on the receiving block. | To lead the control of functioning and regulation. |
| | Malfunction of the circuit TEST. | For revealing malfunction in the circuit TEST to disconnect circuit TEST from the alarm signaler and to lead control operation with out use of mode TEST. |
| | Instability or excess of a level of pulsations of a pressure of a feed. | To check up reliability of contact connections and correctness of a lining of circuits of a feed. To check up serviceability of a power unit for what to lead control operation at a feed from obviously serviceable source. |
| | Malfunction of circuits OUI or TAMPER. | To short-circuit with the crosspieces the target circuits of the receiving block and to lead the control operation. Thus the false notices registered by the calibration unit are an attribute of malfunction OUI (TAMPER) or the calibration unit itself. |

| | |
|---|---|
| The receiving or transmitting block is not serviceable. | To replace the alarm signaler (the faulty block). |
| The note - Malfunction of the alarm signaler blocks is revealed by their replacement by obviously serviceable ones with the subsequent control operation. | |

Alarm signaler regulation

By means of the calibration unit it is possible to check and change:
Formation of notices on alarm and voltage reduction of a feed.

Alarm signaler operating mode.

Borders of speeds of found out crossing of a protected zone.

Level of an accepted signal.

Range of action.

Thresholds of detection.

The order of using of the calibration unit is described in the instruction on the calibration unit.

The technique of regulation of the detection thresholds is adduced below.

For the control and change of small and positive thresholds it is necessary to connect the calibration unit to the alarm signaler and to choose a corresponding mode.

In the verification modes and modes of change of small and positive thresholds in the bottom line of LCD for convenience of adjustment is displayed: a conditional scale on with value of a threshold - symbol #, value of a signal - symbol ↓, the operation of the block of small or positive threshold is signaled by a symbol * in the right bottom corner of the display. If in these modes noises (the changes of the signal which has not been caused by the movement of a person in the protected zone) are displayed it is necessary to arrange on the elimination of their sources (see the control of functioning).

All the control crossings should be carried out with intervals not less than 20 sec. with a speed from 0.5 up to 3 m/s by a normal to an axis of a protected zone, leaving from it on the distance not less than 2m. the weight of the operator who is carrying out the crossings, should be 50-80kg, height in a grouping "having bent" from 0.8 up to 1m. Thus the fulfillment of crossings in the following places is obligatory:

in the middle of a site in both positions;
 in the distance from 15 up to 20m from receiving and transmitting blocks
 in both positions;
 in hollows in "having bent" position.

ATTENTION! For increase of a noise stability of the alarm signaler it is necessary to establish probably greater thresholds of operation.

Test procedure

Walk Test

After tuning the sensitivity, connect 12 or 24V DC power to the system.
 Allow 2 minutes warm-up time.

Make sure that the protected area is cleared of all people.

Cross the middle part of the protected area.

An alarm signal should be received in the control unit for 3 secretary.

Note: Walk Test procedure should be conducted, at least once a year, to confirm proper operation and coverage of the detector.

Remote Test

Apply 5-30 Volts from control unit to the terminal marked TEST (on the transmitter unit).

An alarm signal should be received in the control unit for 3 Sec.

Note: During regular operation it is recommended to conduct remote test every day to confirm proper operation of all system.

SPECIFICATIONS

| | |
|--|--|
| Microwave Frequency | 10.525GHz |
| Modulation Frequency | 1.0KHz |
| Maximum Transmitting Power | 35mW (Continues) 50mW (Peak) |
| Scope (Length of protection zone) | Max. 200 m |
| Lobe Width | Approx. 5 m |
| Lobe Height | Approx. 2.5m |
| Rated Power Supply Voltage | 12...24V |
| Range of Power Supply Voltage | 10.2...24V |
| Current consumption | 70 mA at 24Vdc |
| Relay contacts values | NC 28 Vdc, Maximum current 0.1 A |
| Alarm Period | 3 Sec (Max.) |
| Tamper Switch | N.C 28 Vdc Maximum current 0.1 A - open when cover is removed |
| Detection Speed (Target velocity) | 0.2 ... 10 m/sec |
| Remote testing | Built-in self-test generator simulates actual intrusion signals |
| Flatness of ground | Approx. 0.3m |
| Maximum height of grass on the ground | 0.3 m |
| Maximum height of snow on the ground | 0.5 m |
| Alarm output - switching over of relay contacts for the time | Minimum 3 Sec |
| Dimensions of unit (Trans. / Rec.) w/o bracket | 158 x 113 x 46mm |
| Weight (T, R and accessories) | 1.1kg |
| Operating temperature range | -40 °C ~ +65 °C |
| Relative humidity | Up to 98% |
| Weatherproofing | All openings with gasket and sealed Conformal coated circuit board Against snow and rain up to 30mm/hour |

* Specifications are subject to change without prior notice.